

NOTES:

1. TO INSPECT ASSEMBLY, FOLLOW FIRST ARTICLE AND IN PROCESS INSPECTION SHEET.

BILL OF MATERIAL (CURRENT LEVEL)

ITEM	PT/ASSY	DESCRIPTION	TYPE	QTY.
1	5086SQ	42" GRAB BAR ASM	ASSEMBLY	1
2	1995	MOUNTING FLANGE	PART	3
3	199X	GRAB BAR MOUNTING HARDWARE PACK	ASSEMBLY	3
4	40677	DECORATIVE RING	PART	3
5	92308	SCRW, M5 X 5 SKT HD CUP PT W/ SELF LOC SS	PART	3

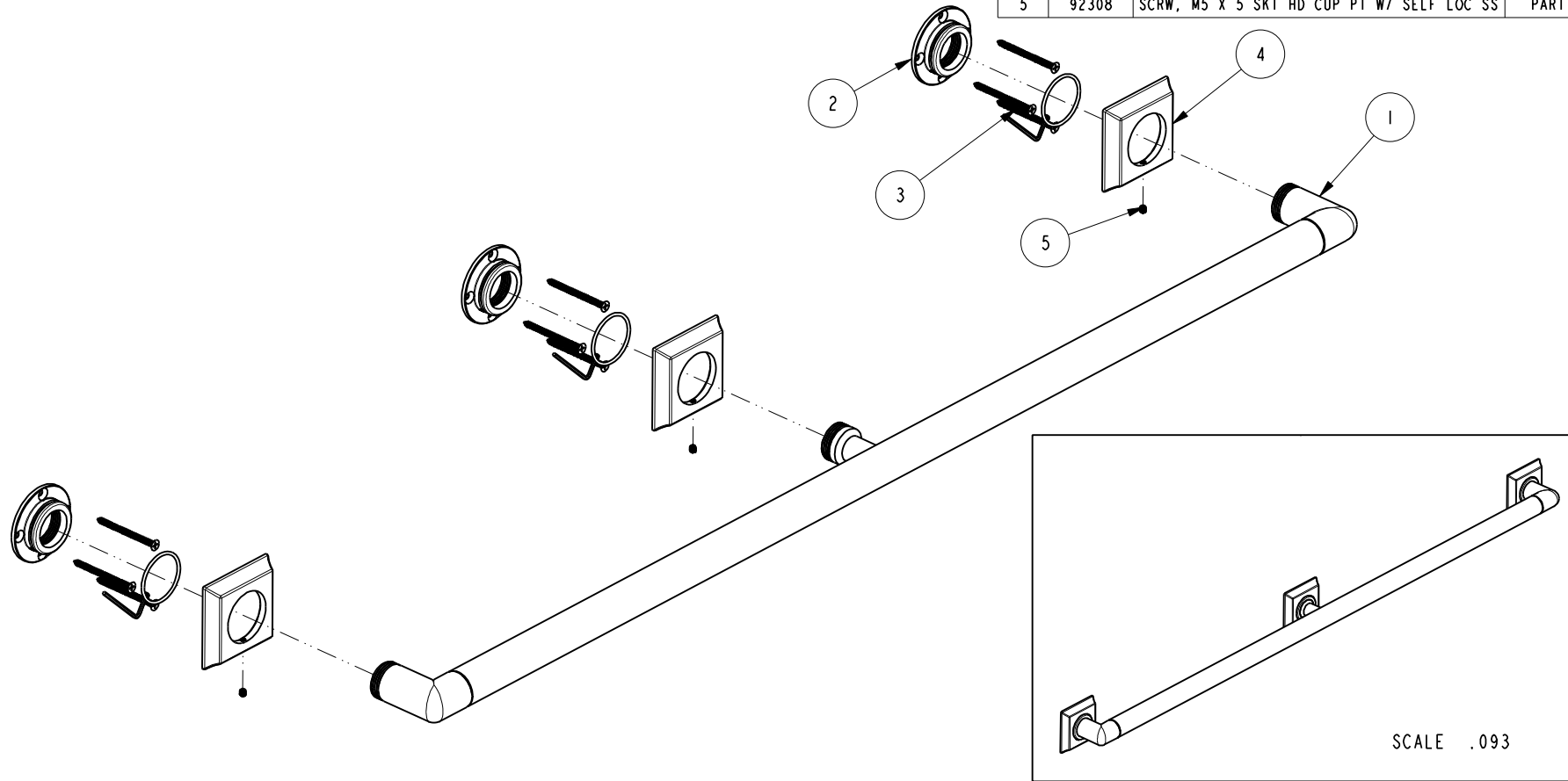

UNITS ARE: INCHES [MM]
 TOLERANCES ARE:
 FRACTIONS DECIMALS ANGLES
 $\pm 1/16"$.X $\pm .1$ [2.5] $\pm 1^\circ$
 .XX $\pm .06$ [1.5]
 (X.XXX) DENOTES CRITICAL DIMS.
 ALL THREADS ARE CRITICAL

BRASSTECH 2001 CARNEGIE AVE.
 INCORPORATED SANTA ANA, CA 92705
 (949) 417-5207

GRAB BAR 42"

DRAWN JINSON 06/22/21
 CHECKED R.S. 06/22/21
 APPROVED R.S. 06/22/21

DWG NO. 2570-3942 REV B
 SCALE .188 REF. - SHEET 1 OF 2

ZONE	REV	DESCRIPTION	DATE	APPROVED
-	B	EN-4300i	06/22/21	R.S.
-	A	EN-4143	03/20/20	J.M.
-	-	EN-3279b	07/13/17	J.M.

COPYRIGHT 2005 BRASSTECH, INC.
 THESE DRAWINGS AND THE DESIGNS
 DEPICTED HEREIN ARE THE PROPRIETARY
 PROPERTY OF BRASSTECH. ANY USE
 OR REPRODUCTION IS SUBJECT TO
 THE EXPRESS APPROVAL OF BRASSTECH.
 UNAUTHORIZED USE IS STRICTLY
 PROHIBITED. ALL RIGHTS RESERVED.

TESTING	-	-	-
ASSEMBLY	-	-	-
PLATING	-	-	-
POLISHING	-	NEXT ASSY	USED ON
MACHINING	-	APPLICATION	
TOOLING FIXTURE #	REMOVE ALL BURRS AND SHARP EDGES		

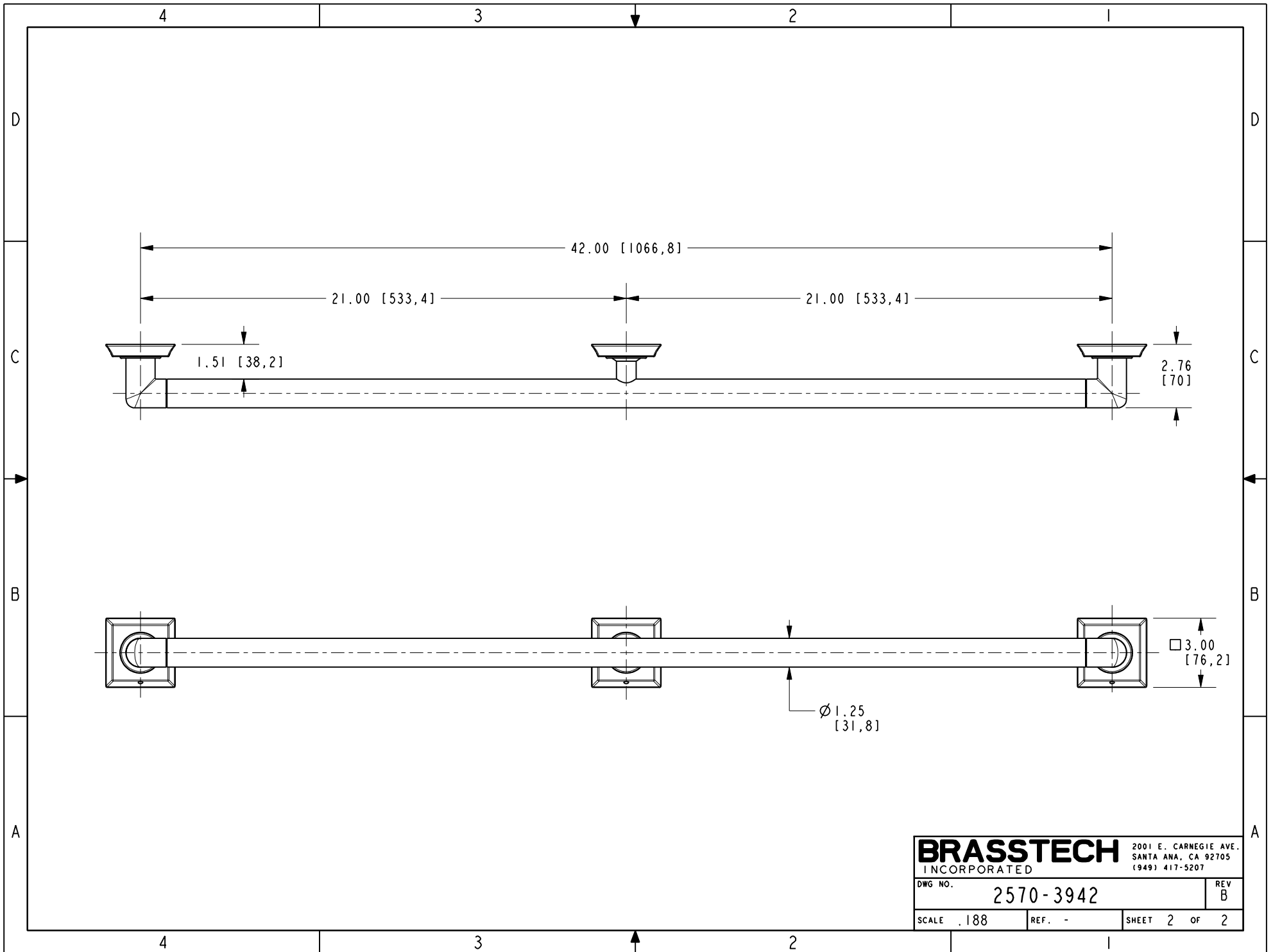

BRASSTECH		2001 E. CARNEGIE AVE.
INCORPORATED		SANTA ANA, CA 92705
		(949) 417-5207
DWG NO.	2570-3942	REV B
SCALE .188	REF. -	SHEET 2 OF 2